

Tying Shit Together

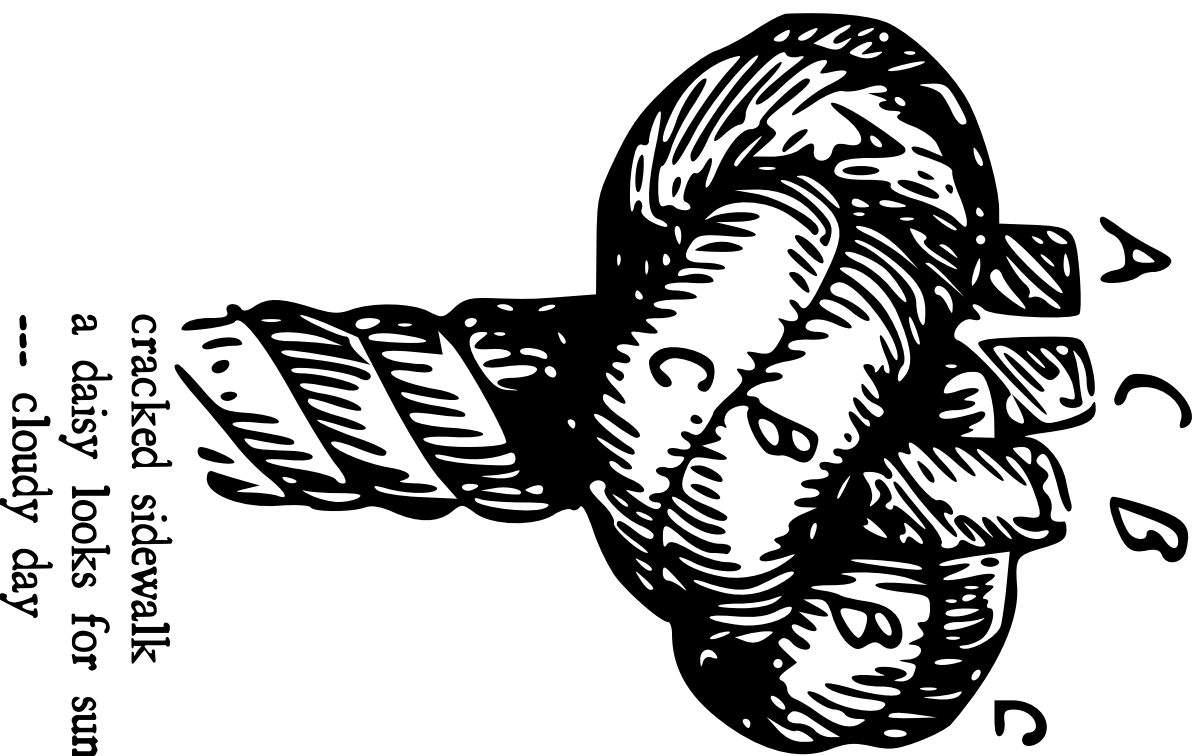

cracked sidewalk
a daisy looks for sun
--- cloudy day

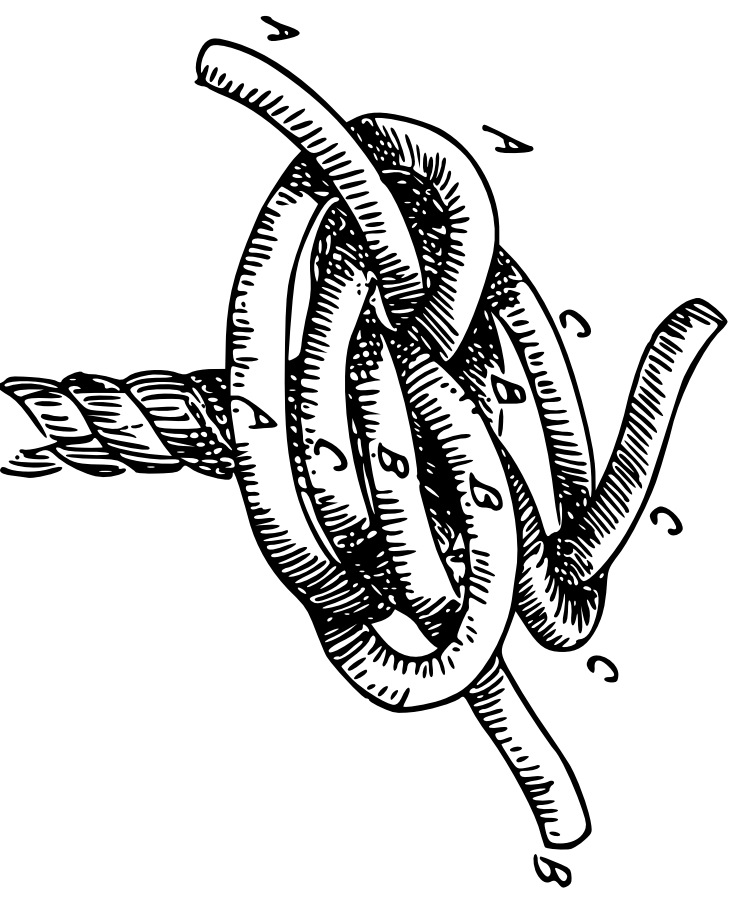

This text was compiled by J. L. d. V.
Please enjoy responsibly. No copyright, 2010.

5. The Hitch · Taut Line Hitch

Whether you're building a blanket fort, or hanging up a banner, knowing a few basic knots can be an invaluable addition to your DIY arsenal. This zine isn't an exhaustive catalog, but a quick-£3-dirty guide.

The 5 types of knots are:

1. Stoppers (tie off ends)
2. Bends (tie rope-to-rope)
3. Loops (go around stuff)
4. Binders (close tightly)
5. Hitches (tie onto stuff)

The best way to learn the knots in this zine is to just tie them a few times.

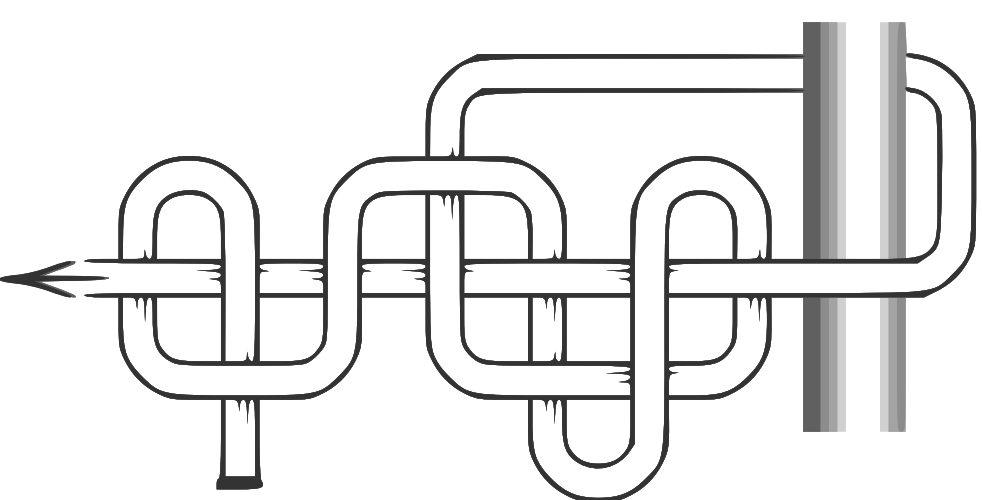

You can grab the knot and move it by pulling, thus drawing the line taut. Useful for tent pegs, e.g.

5. The Hitch · Buntline Hitch

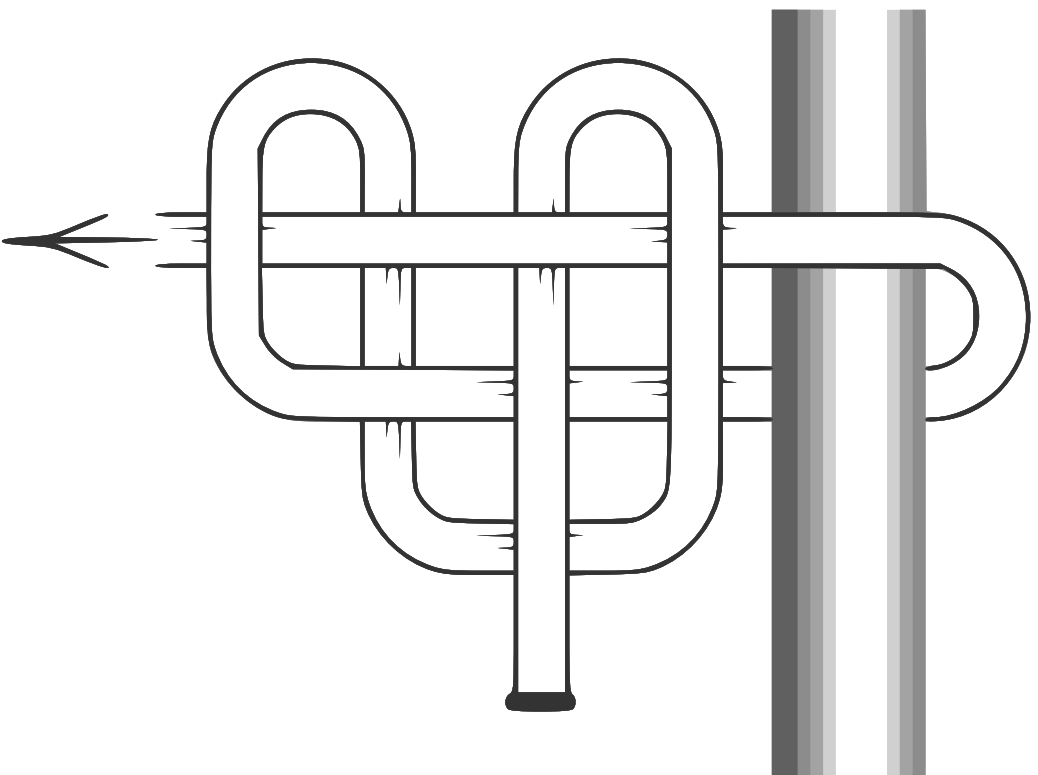

“Buntline” is some sort of sailing term. It’s a straight-forward hitch, for all your hitching needs.

1. The Stopper · Overhand Knot

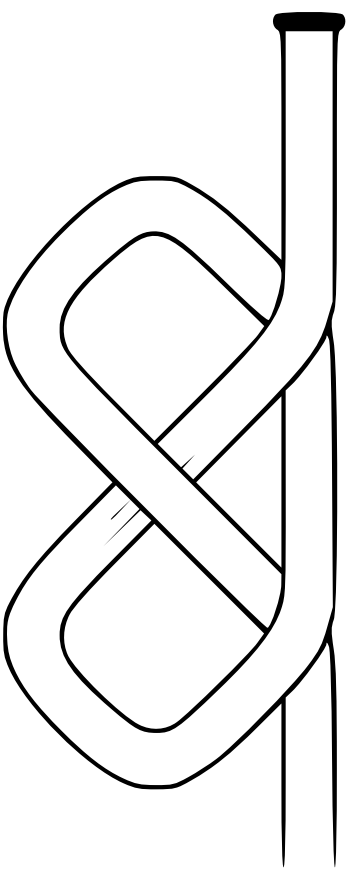

This is not the world’s best stopper, but you know what? Who cares! You already know how to tie this one & it’s good enough most of the time, so go ahead and keep on using it when you need a stopper. But, when you need to actually tie something to something else, please use one of the other knots in this zine.

2. The Bend · Zeppelin Bend

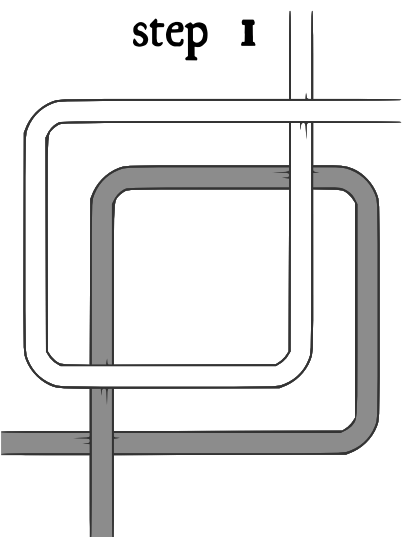

step 1

If you have two shorter bits of rope & want one longer one then this is the way to go. It used to be used to tie down zeppelins.

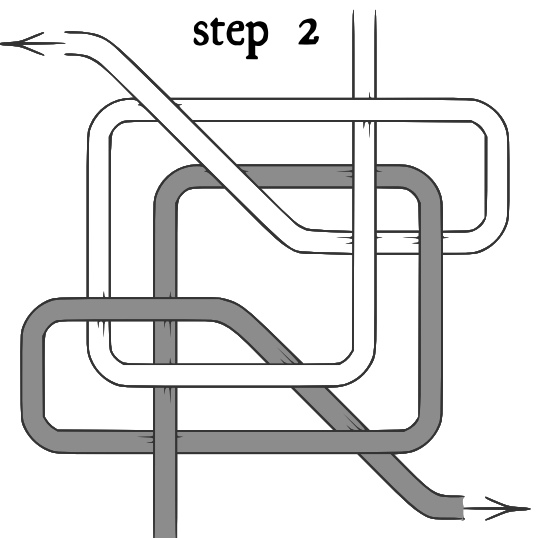

step 2

Constrictor Knot in the Bight

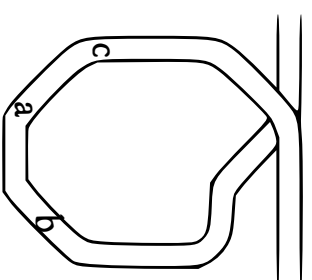

(1) Form a loop.

(2) Take the bottom of that loop and move it up, twisting it in the process.

(3) Fold the loop you've brought up, back over & slip the knot over whatever you're tying.

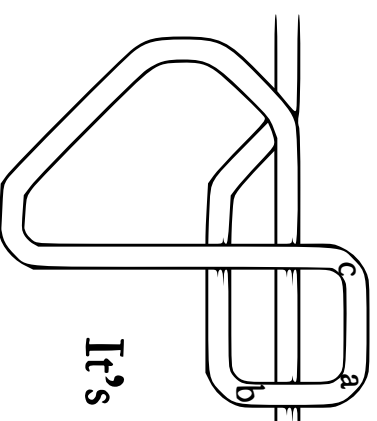

It's easier than it sounds.

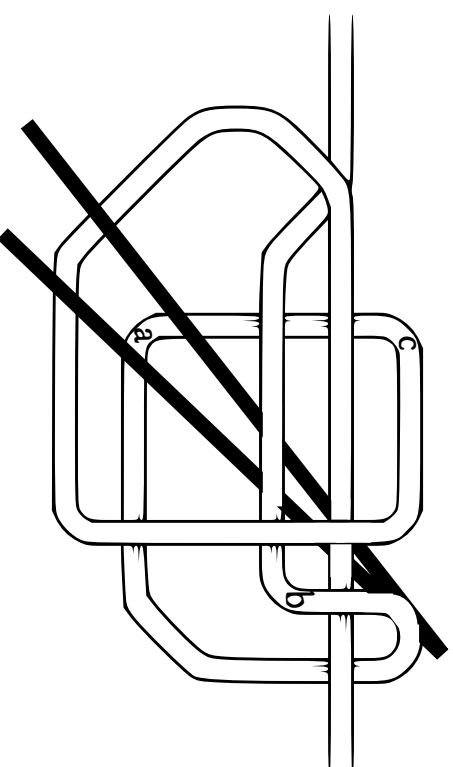

4. The Binder · Constrictor Knot

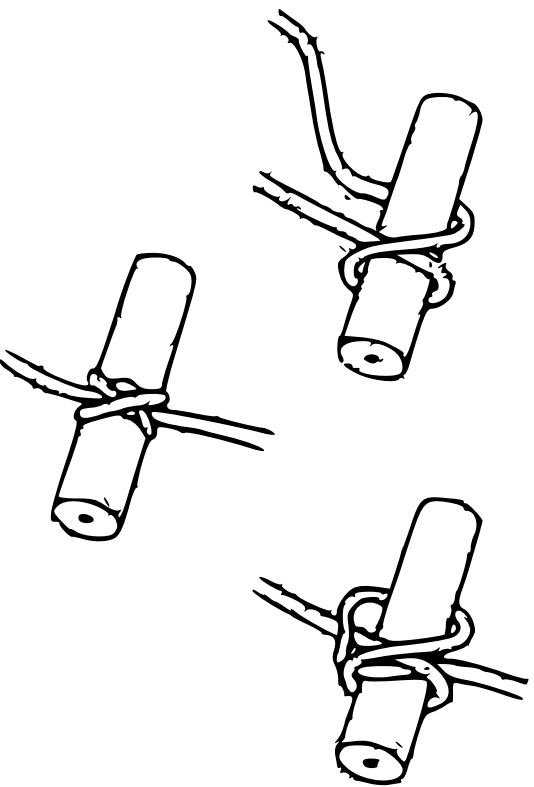

This is a very strong knot. You can use it for pretty much anything, including as a hitch. The best part is that it can be tied in the bight. That's the fancy way of saying you can tie it in the middle of a piece of rope, i.e. you don't need access to the ends of the rope.

2. The Bend · Sheet Bend

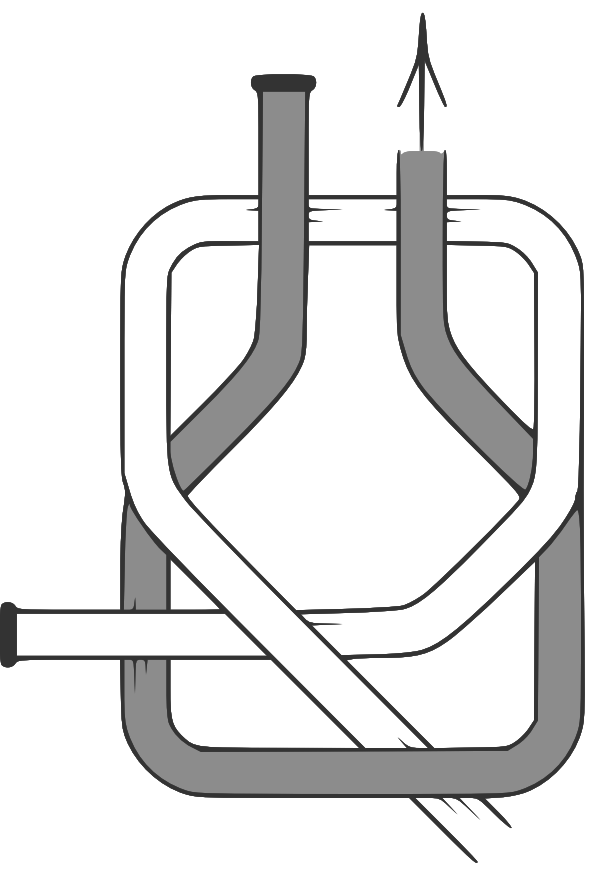

This isn't as strong as the zeppelin, but it's sometimes easier to tie. You don't have to learn both. If the ropes aren't the same girth, the gray one should be the bigger of the two.

3. The Loop · Water Bowline

This loop won't come undone & can take a strain. If you want a lasso style slip-knot, make a small loop and then slip the end of the rope through it to make a bigger loop.

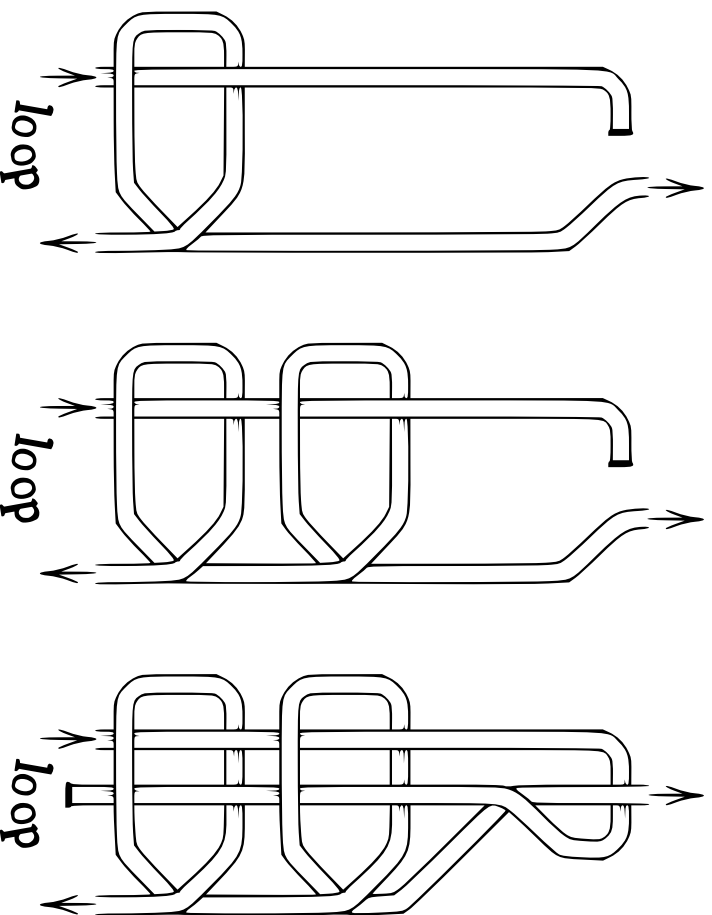

Interlude · Shoe Laces

Here's a nifty and fast way to tie your shoes, created by: Ian W. Fieggen.

